

## ***InterActions* Unit 4 Cycle2 Sample Quiz**

**REMEMBER** exams are given for the last cycle in a unit. They are comprehensive. So practice taking the Unit 4 Cycle 1 quiz again along with this practice exam. This practice exam only asks questions about Unit 4 Cycle 2.

See the Scientists' Consensus Sheets for assistance.

1. A hot iron is turned off and cools down to room temperature. The iron cools because
  - a. the iron does not hold heat very well.
  - b. the room transfers cold energy to the iron
  - c. heat energy is transferred from the warm iron to the cooler room.
  - d. the thermal energy is destroyed during an interaction with the room.

2. To check if the iron is hot, you place your hand near the iron and feel that it is warm without touching it. The interaction between you and the iron is

- a. a heat-conduction interaction.
- b. an infrared-radiation interaction
- c. a thermal interaction.
- d. a phase change interaction.

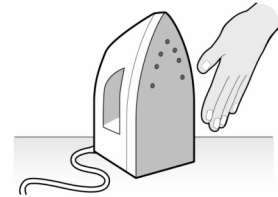

3. A warm bottle of juice is placed into the refrigerator. Which diagram best describes the interaction between the cool air in the refrigerator and the juice bottle.

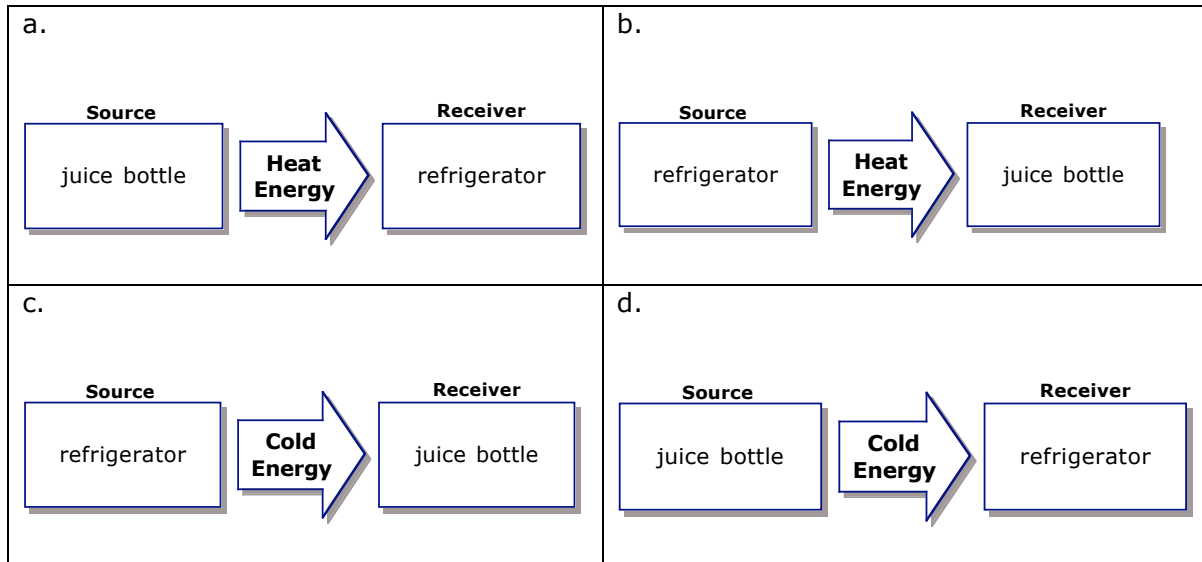
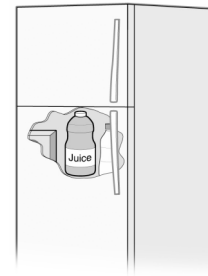

4. After a while the juice bottle cools down. You get the cold juice bottle out of the fridge. The interaction between your hand and the juice bottle is

- a heat-conduction interaction.
- an infrared-radiation interaction
- a thermal interaction.
- a phase change interaction.

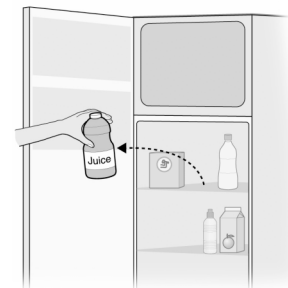

5. Which diagram best describes the interaction between the cold juice bottle and your hand?

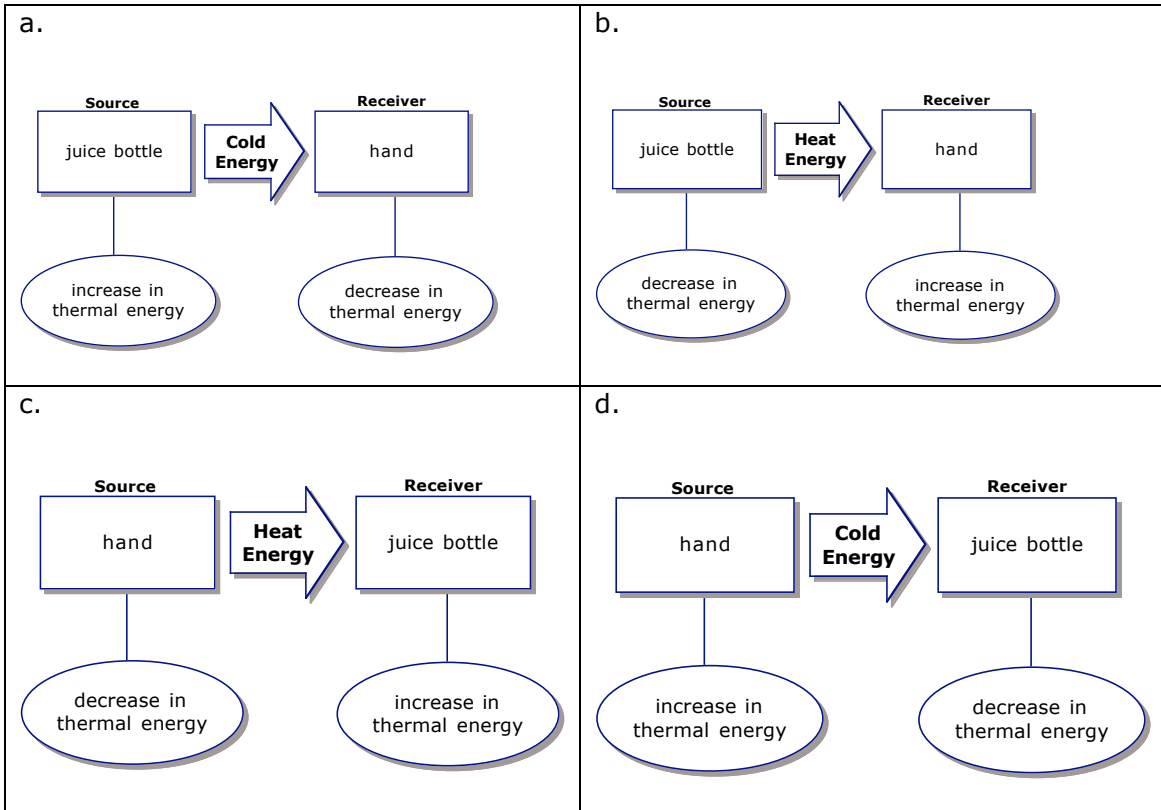

6. A motor has an energy input of 300 units. The motor increases in thermal energy by 70 units. What is the total *output energy* of the motor?

- a. There is not enough information to determine the total output energy of the motor.
- b. 370 units.
- c. 300 units.
- d. 230 units.

7. George is on his skateboard moving with a certain amount of motion energy. He stops pushing forward and begins to slow down. While he is slowing down most of the energy is transformed into thermal energy of the rubbing wheel parts of the skateboard. The rest of the energy
- is destroyed during the friction interaction between the wheel parts.
  - disappears and cannot be found anywhere else.
  - is transformed into the motion energy of the scooter.
  - is transferred to the surroundings.
8. Tom boils some water to make a cup of tea. While the water is boiling the temperature
- increases.
  - decreases.
  - stays the same.
  - There is not enough information to say.
9. When water boils and changes from *a liquid to a gas* its stored phase energy
- increases.
  - decreases.
  - stays the same.
  - There is not enough information to say.
10. When water boils and changes from *a liquid to a gas* its thermal energy
- increases.
  - decreases.
  - stays the same.
  - There is not enough information to say.

11. Mom melted chocolate and poured it into molds. She then put it in the fridge to cool. She left it overnight, so it stayed in the fridge even after the chocolate became hard. Which graph best shows the temperature of the chocolate while in the fridge.

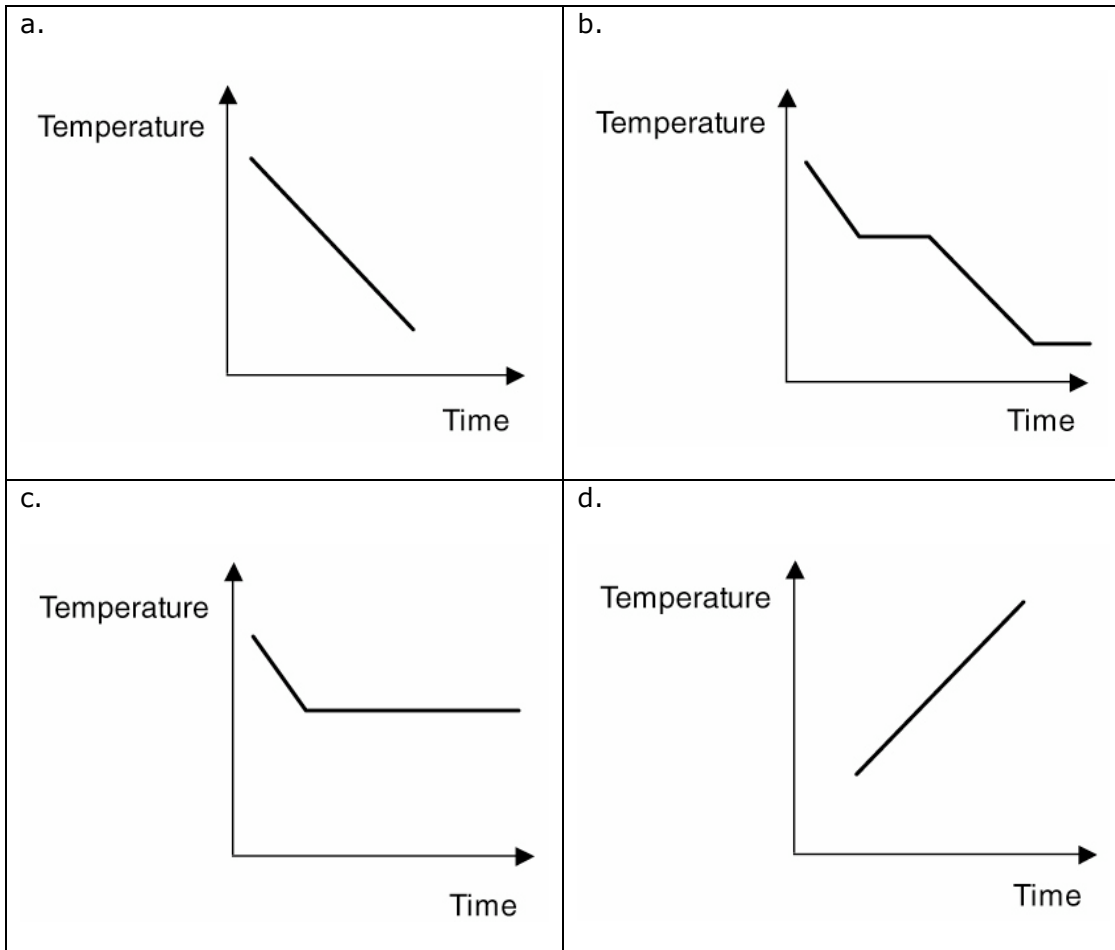

12. The energy diagram shown describes what happens as water freezes in a freezer. Choose the best answer for completing the diagram.

- Increase in thermal energy.
- Decrease in thermal energy.
- Increase in stored phase energy.
- Decrease in stored phase energy.

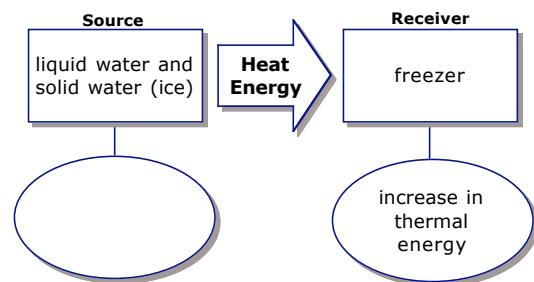

13. A light bulb transforms 5% of its energy input to light energy. The rest of the energy

- a. increases the bulb's thermal energy and the thermal energy of the surroundings.
- b. decreases the bulb's thermal energy and the energy of the surroundings.
- c. disappears in the bulb.
- d. is destroyed.

14. How could you improve the efficiency of a skateboard?

- a. Increase the amount of heat it produces due to rubbing wheel parts.
- b. Reduce the amount of heat it produces due to rubbing wheel parts.
- c. Increase its speed.
- d. is destroyed.

## Learning About Questions

### Activity 9 Reflection of Light

15. Which diagram best describes how shadows are formed?

A.

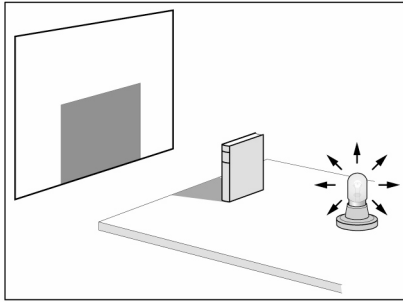

B.

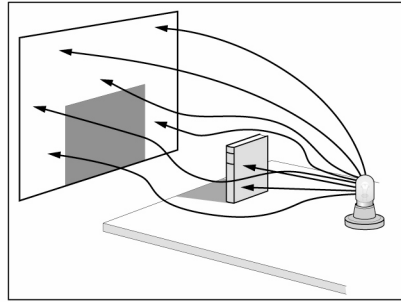

C.

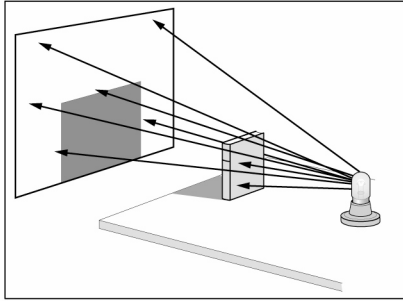

D.

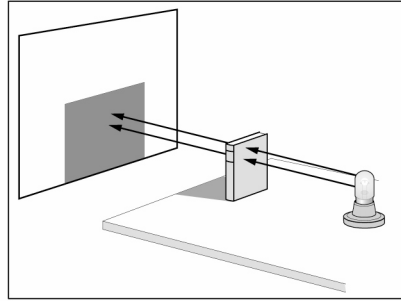

16. Which light ray diagram best describes how the girl can see the book?

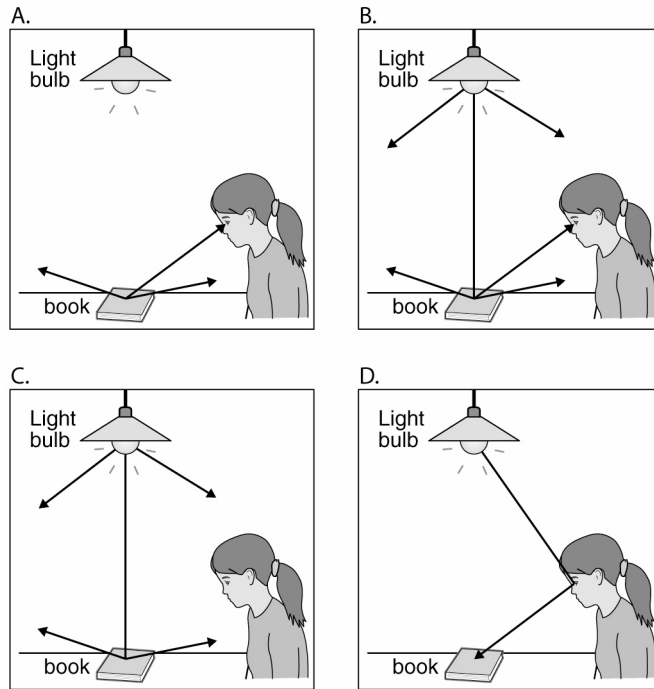

**Activity 10**

17. When light goes from air into glass the light

- a. travels in the same direction in a straight line
- b. curves
- c. changes direction but still goes in a straight line
- d. spreads out



**Activity 11**

18. Which object absorbs the most light energy?

- a. A red object
- b. A shiny white object
- c. A non-shiny white object
- d. A transparent object

**Activity 12**

19. Which energy source is NOT renewable?

- a. Solar Energy
- b. Nuclear Energy
- c. Wind Energy
- d. Geothermal Energy

**Activity 13**

20. Astronomers can determine the temperature of a star by its

- a. luminosity
- b. mass
- c. size
- d. color